

TYPE FRS

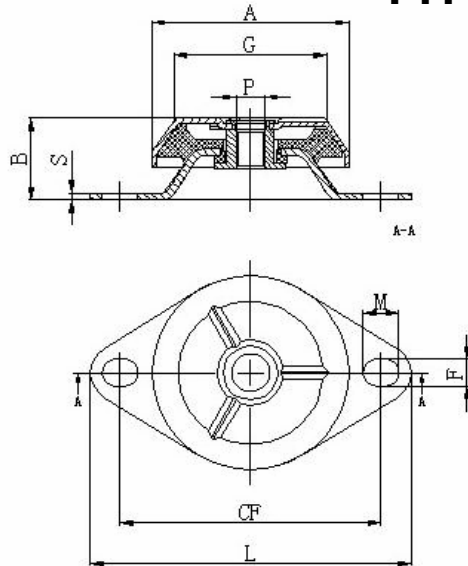

Item Fibet	Hardness (IRHD)	A	B	P	FxM	CF	L	S	Average Stiffness (Kg/mm)	Max. Load (Kg)	Max Deflec. (mm)
Item 型号	橡胶硬度 IRHD (daN/mm)	A	B	P	FxM	CF	L	S	Average Stiffness 平均负荷(Kg/mm)	Max Load 最大荷重(kg)	Max Deflec. 最大压缩量 (mm)
FRS63x3510W	40								7.0	30.0	4.3
FRS63x3510M	60	63	35	M10	9x12	88	110	2	15.8	60.0	3.8
FRS78x3510W	40										
FRS78x3510M	60	78	35	M10	11.5X15	110	135	3			
FRS78x3512W	40										
FRS78x3512M	60	78	35	M12	11.5X15	110	135	3			
FRS83x3510W	40								17.8	80.0	4.5
FRS83x3510M	60	83	35	M10	11.5X15	110	135	3	44.5	180.0	4.0
FRS83x3512W	40								17.8	80.0	4.5
FRS83x3512M	60	83	35	M12	11.5X15	110	135	3	44.5	180.0	4.0
FRS92x4210W	40										
FRS92x4210M	60	92	42	M10	10X15	123.5	150	3			
FRS92x4212W	40										
FRS92x4212M	60	92	42	M12	10X15	123.5	150	3			
FRS92x4212H	75										
FRS106x4212W	40								33.5	167.0	5.0
FRS106x4212M	60	106	42	M12	13X19	143	175	4	67.0	335.0	5.0
FRS125x4812W	40										
FRS125x4812M	60	125	48	M12	14.5X20	156	192	4			
FRS125x4816W	40										
FRS125x4816M	60	125	48	M16	14.5X20	156	192	4			
FBS150x5416W	40								37.5	450.0	12.0
FBS150x5416M	60	150	54	M16	14X18	182	218	4	78.7	800.0	10.2

TYPE FRSQ

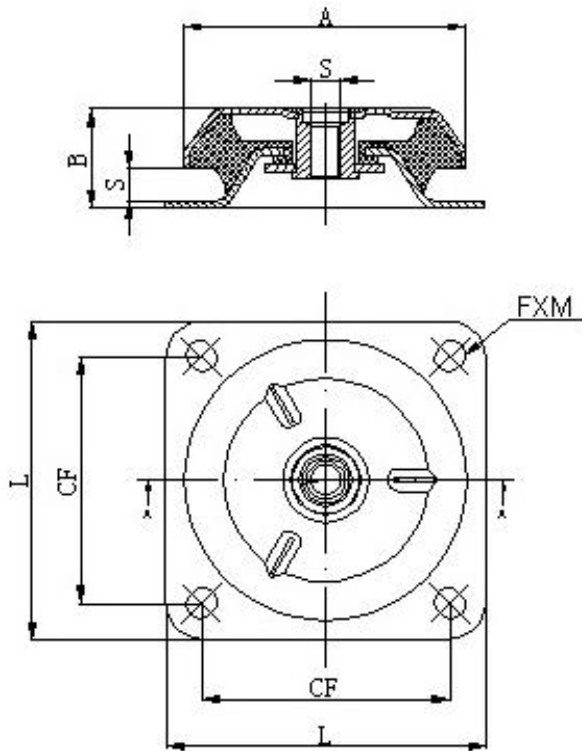

Item Fibet	Hardness (IRHD)	A	B	P	FxM	CF	L	S	Average Stiffness (Kg/mm)	Max. Load (Kg)	Max Deflec. (mm)
Item 型号	橡胶硬度 IRHD (daN/mm)	A	B	P	FxM	CF	L	S	Average Stiffness 平均负荷 (Kg/mm)	Max Load 最大荷重 (kg)	Max Deflec. 最大压缩量 (mm)
FBSQ150x5416W	40	150	54	M16	14X18	182	218	4	37.5	450.0	12.0
FBSQ150x5416M	60								78.7	800.0	10.2
FBSQ180x8620W	40	180	86	M20	18.5X21	150	190	4	59.2	900.0	15.2
FBSQ180x8620M	60								127.0	1700.0	12.4